

PRODUCTS

CUSTOM CAPABILITIES

PART BUILDER

GLOBAL DISTRIBUTION

ORDER ONLINE

Swage Threaded Standoffs

Round or Hex

2-56 Thread x .156 O.D. (5/32")

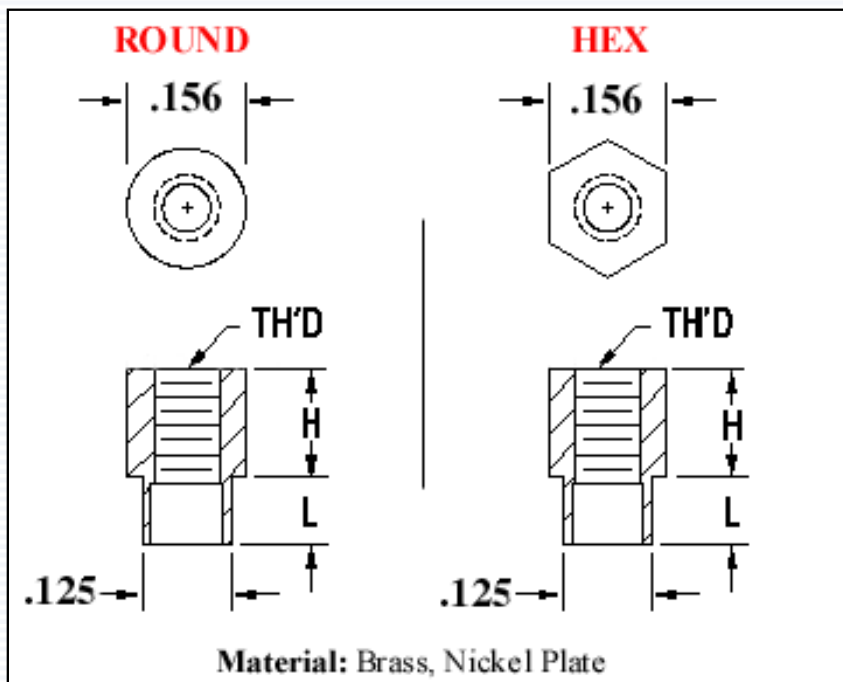

Use Staking Tool: **Cat. No. TL-19**

Round Cat. No.	"H"	"L"	For Panel Thickness	HEX Cat. No.
1589-2	.125 [3,17]	.109 [2,77]	1/16	1731-2
1589-3	.125 [3,17]	.140 [3,56]	3/32	1731-3
1590-2	.187 [4,75]	.109 [2,77]	1/16	1734-2
1590-3	.187 [4,75]	.140 [3,56]	3/32	1734-3
1591-2	.250 [6,35]	.109 [2,77]	1/16	1740-2
1591-3	.250 [6,35]	.140 [3,56]	3/32	1740-3
1596-2	.375 [9,52]	.109 [2,77]	1/16	1743-2
1596-3	.375 [9,52]	.140 [3,56]	3/32	1743-3

[Click to Request Samples](#)

[VIEW PRODUCT OVERVIEW](#)

4-40 Thread x .187 O.D. (3/16")

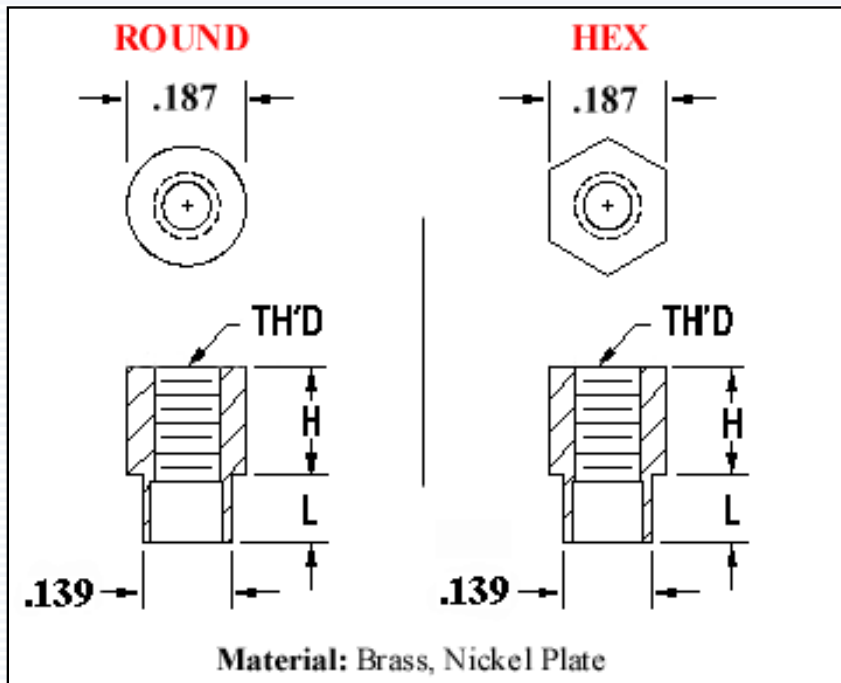

Use Staking Tool: Special Order

Round Cat. No.	"H"	"L"	For Panel Thickness	HEX Cat. No.
2260-2	.125 [3,17]	.109 [2,77]	1/16	2270-2
2261-2	.187 [4,75]	.109 [2,77]	1/16	2271-2
2262-2	.250 [6,35]	.109 [2,77]	1/16	2272-2
2263-2	.375 [9,52]	.109 [2,77]	1/16	2273-2
2264-2	.500 [12,7]	.109 [2,77]	1/16	2274-2

[Click to Request Samples](#)

VIEW PRODUCT OVERVIEW

4/40 Thread x .250 O.D. (1/4")

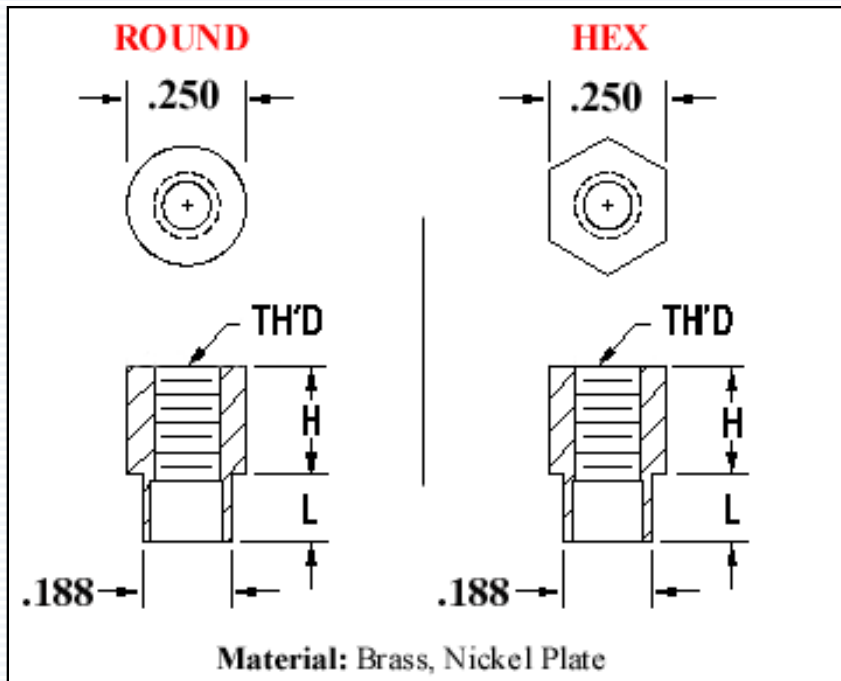

Use Staking Tool: Cat. No. TL-20

Round Cat. No.	"H"	"L"	For Panel Thickness	HEX Cat. No.
1560A	.125 [3,17]	.109 [2,77]	1/16	1653-2
1560F	.125 [3,17]	.140 [3,56]	3/32	1653-3
1790-2	.187 [4,75]	.109 [2,77]	1/16	1746-2
1790-3	.187 [4,75]	.140 [3,56]	3/32	1746-3
1650-2	.250 [6,35]	.109 [2,77]	1/16	1627-2
1650-3	.250 [6,35]	.140 [3,56]	3/32	1627-3
1651-2	.375 [9,52]	.109 [2,77]	1/16	1628-2

1651-3	.375 [9,52]	.140 [3,56]	3/32	1628-3
1623-2	.500 [12,7]	.109 [2,77]	1/16	1629-2
1623-3	.500 [12,7]	.140 [3,56]	3/32	1629-3
1624-2	.625 [15,88]	.109 [2,77]	1/16	1654-2
1624-3	.625 [15,88]	.140 [3,56]	3/32	1654-3
1625-2	.750 [19,05]	.109 [2,77]	1/16	1655-2
1625-3	.750 [19,05]	.140 [3,56]	3/32	1655-3
1792-2	.875 [22,22]	.109 [2,77]	1/16	1749-2
1792-3	.875 [22,22]	.140 [3,56]	3/32	1749-3
1652-2	1.00 [25,4]	.109 [2,77]	1/16	1630-2
1652-3	1.00 [25,4]	.140 [3,56]	3/32	1630-3

[Click to Request Samples](#)

[VIEW PRODUCT OVERVIEW](#)

6/32 Thread x .250 O.D. (1/4")

Use Staking Tool: Cat. No. TL-21				
Round Cat. No.	"H"	"L"	For Panel Thickness	HEX Cat. No.
1560B	.125 [3,17]	.109 [2,77]	1/16	1620-2
1560C	.125 [3,17]	.140 [3,56]	3/32	1620-3
1612-2	.187 [4,75]	.109 [2,77]	1/16	1752-2

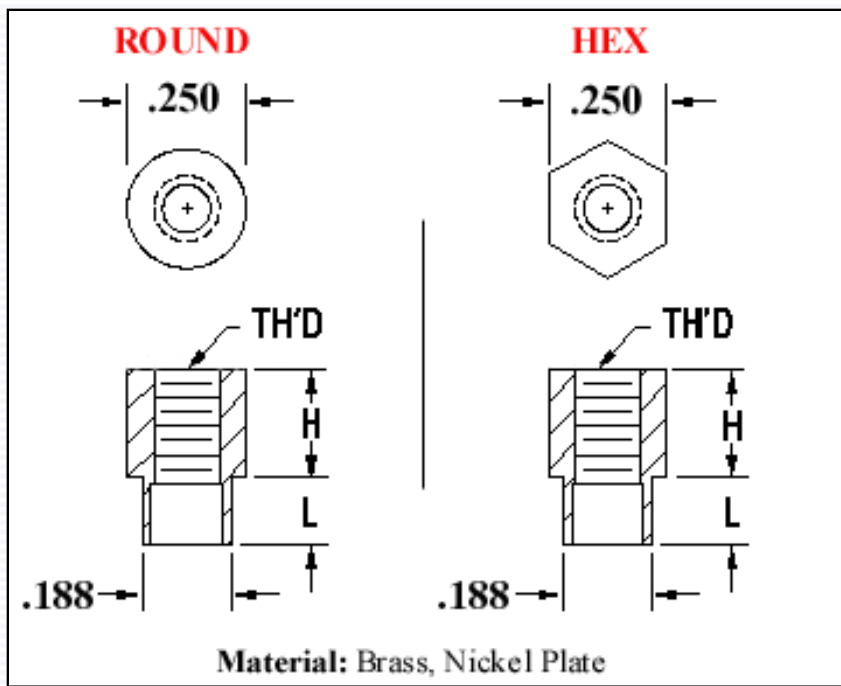

1612-3	.187 [4,75]	.140 [3,56]	3/32	1752-3
1546	.250 [6,35]	.109 [2,77]	1/16	1621-2
1546B	.250 [6,35]	.140 [3,56]	3/32	1621-3
1546D	.250 [6,35]	.171 [4,34]	1/8	1621-4
1561B	.375 [9,52]	.109 [2,77]	1/16	1622-2
1561C	.375 [9,52]	.140 [3,56]	3/32	1622-3
1561D	.375 [9,52]	.171 [4,34]	1/8	1622-4
1604-2	.500 [12,7]	.109 [2,77]	1/16	1758-2
1604-3	.500 [12,7]	.140 [3,56]	3/32	1758-3
1604-4	.500 [12,7]	.171 [4,34]	1/8	1758-4
1605-2	.625 [15,88]	.109 [2,77]	1/16	1759-2
1605-3	.625 [15,88]	.140 [3,56]	3/32	1759-3
1608-2	.750 [19,05]	.109 [2,77]	1/16	1761-2
1608-3	.750 [19,05]	.140 [3,56]	3/32	1761-3
1796-2	.875 [22,22]	.109 [2,77]	1/16	1775-2
1796-3	.875 [22,22]	.140 [3,56]	3/32	1775-3
1609-2	1.00 [25,4]	.109 [2,77]	1/16	1784-2
1609-3	1.00 [25,4]	.140 [3,56]	3/32	1784-3

[Click to Request Samples](#)

[VIEW PRODUCT OVERVIEW](#)

© 2005 Keystone Electronics Corp. | 31-07 20th Road | Astoria, NY 11105 | 718-956-8900 | 800-221-5510 | 718-956-9040
fax | www.keyelco.com